



Schindler 2400

An eye for mass and love for detail
is not a contradiction in terms.

When it comes to our goods elevators,
those terms are our guide.





The Schindler 2400 fits.

It can be used anywhere. In shopping centres and convention buildings, in airports and train stations, in hotels, schools, and office complexes. An absolutely presentable elevator.



satility



Availability

The Schindler 2400 keeps running.
With absolute reliability. Whoever you want and
whenever you want. A simply uncomplicated matter.



ity



Longe

The Schindler 2400 keeps its promises.
Thanks to its robust technology, high-quality materials, and practical equipment features. A consummate achievement.

A photograph of a woman with long, wavy brown hair wearing a red, sequined, halter-neck dress. She is embracing a man from behind. The man is wearing a white long-sleeved shirt and grey trousers. They are standing on a balcony with a glass railing. The background shows a blurred view of a city or building. The word "vity" is written in white, lowercase letters on the left side of the image.

vity



Are you looking for an intelligent solution? No need to look very far.

Brisk movement is our business

You need an elevator for a building with high visitor traffic? One that can hold shopping carts as well as people, and transport various types of goods? Then the Schindler 2400 is the right choice.

We have developed an extra-large goods elevator especially for high-traffic public and private buildings. It fits in hotels as well as it does in shopping centres, office buildings, hospitals, train or underground train stations. It's economical to purchase and robust in use.

Simple solutions are our approach

With the Schindler 2400, we rely on consistent system engineering and high standardisation. For this reason, we've given this elevator a modular construction. It is based on pre-assembled components that reflect the latest technology. The elevator's availability is absolutely reliable. Depending upon your needs, the drive may be electromechanical or electro-hydraulic.

Safety comes first with us

We monitor the system 24 hours a day, 365 days a year. That way, problems can be corrected before they affect you. Even during the night.

We only grant access to those you wish to have it

With high incoming traffic, it's important to manage the flow of traffic as efficiently as possible. This is where our registered-destination control system does a great job. Together with Schindler ID®, the elevator can be made available only to specific persons at specific times if desired. There are practically no limits to the ways this proven technology can be configured to meet your needs. An ingenious system.

We're happy to take on commitments

The elevator meets all significant legal safety regulations and standards.

You can call us into action from any location

The Schindler 2400 saves you time and money. Pre-defined components and mandatory data, ease planning and shorten delivery times – for a single system or a group of up to four elevators. The Schindler 2600 freight elevator and the Schindler 2500 bed elevator belong to the same platform as the goods elevator.

Notice

We reserve the right to make technical modifications and to alter specifications, options and colours.

All cars and options presented in this brochure are intended to serve as representations of our products. Colours and materials as shown may vary from the original.

Car interior: custom, stainless steel brushed finish

Basic data

Load capacity	1000–6300 kg, 8–84 persons
Travel height	65 meters; max. 21 stops
Entrance	One-sided or two-sided access
Door width	900–3100 mm
Door height	2000–2400 mm
Drive	Roped or hydraulic
Speed	0.25 to 1.6 meters per second
Control	Collective control for groups up to 4; registered-destination control
Equipment	Flexible range of equipment

Sustainability is the smart combination of technology and efficiency. The same applies to our elevators.

The employees of the French telephone company Bouygues Télécom work under the green roof of France's first positive-energy commercial building. This building creates more energy than it consumes.

Bouygues Immobilier chose the Schindler 2400 to be the right elevator for its HQE (Haute Qualité Environnementale) approach. With a perfect balance of energy efficiency and performance, the Schindler 2400 transports people and goods swiftly and safely.

Ecological materials and sustainable technologies.
This building offers great comfort.



We support sustainability

Let us make your building more sustainable. We designed the Schindler 2400 to be highly efficient in performance and energy usage. For us every detail counts.

We care for the environment

The daily operation of a building has the biggest impact on the environment – the same applies to elevators. That’s why we made sure that the Schindler 2400 is energy-efficient during operation. Using less energy conserves our natural resources and lowers overall building costs.

We focus on efficiency

The Schindler 2400 is a fully engineered, smart system. It is strong enough to transport many people yet uses the minimum energy to do so. All parts are perfectly adjusted to each other. From drives, to controls, to doors and to cabins – each and every component contributes to this elevator’s efficiency.

We assess our elevators

How do you know that this elevator is energy efficient? We measure it. Ratings run by independent third parties show that the Schindler 2400 can provide an energy efficiency classification in the “green” range. It is always good to rely on facts.

Total environmental impact % by product phase

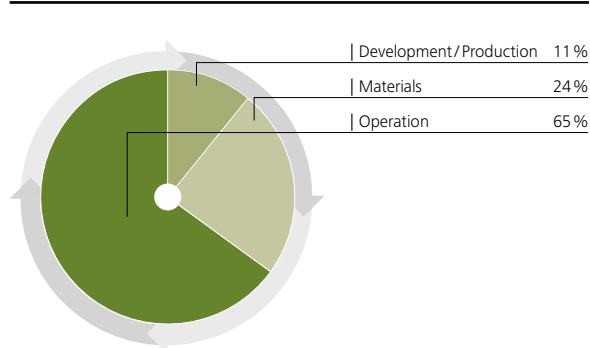

The energy consumed while an elevator is in service (operation phase) accounts for two-thirds of its environmental impact.

Energy efficiency classes

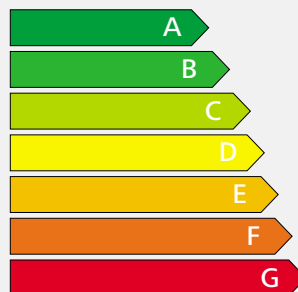

The measurement standard is VDI 4707 established in March 2009 by the Association of German Engineers. Energy efficiency classification can vary depending on elevator configuration.

For the development of our systems, we jump over every hurdle. Even the hurdles of our own intuition.

Traction elevator system

The Schindler 2400 can be driven electro-mechanically for loads of 1000 kg to 4000 kg. This traction elevator system is especially suitable for complexes with high levels of traffic. Where multiple elevators neighbour each other, coordinating them with each other can increase the efficiency of transport. The freight elevators can operate with up to 4 tonnes without a machine room. That saves significant space in buildings.

Drive

The highly efficient permanent-magnet drive of the Schindler 2400 runs without gears allowing for a smooth, quality ride. Because it is relatively small and functions quietly, it represents the ideal solution for machine room-less elevators. The frequency-controlled drive enables a direct power transfer avoiding a loss of power. By allowing a stable start without a high peak current, it quickly reaches a low energy consumption level.

Control

The microprocessor control of the Schindler 2400 performs a wide variety of tasks for individual systems as well as for groups of up to four elevators. The system switches the car lights and ventilation into stand-by mode when not in use. Multi-bus control architecture reduces cabling, material and waste. For an efficient and short ride time for passengers, you may select from the following typical control types: Pick-up, up or down collective, or collective/selective control for groups of up to four elevators. The control is built into the top floor next to the landing door, which saves space.

Destination Control

The Schindler Miconic 10 destination control system is available as a standard option. Passengers select their floor before entering the elevator, this allows them to be grouped according to their destination. The result for the building is clear – energy savings and a significant improvement in traffic management.

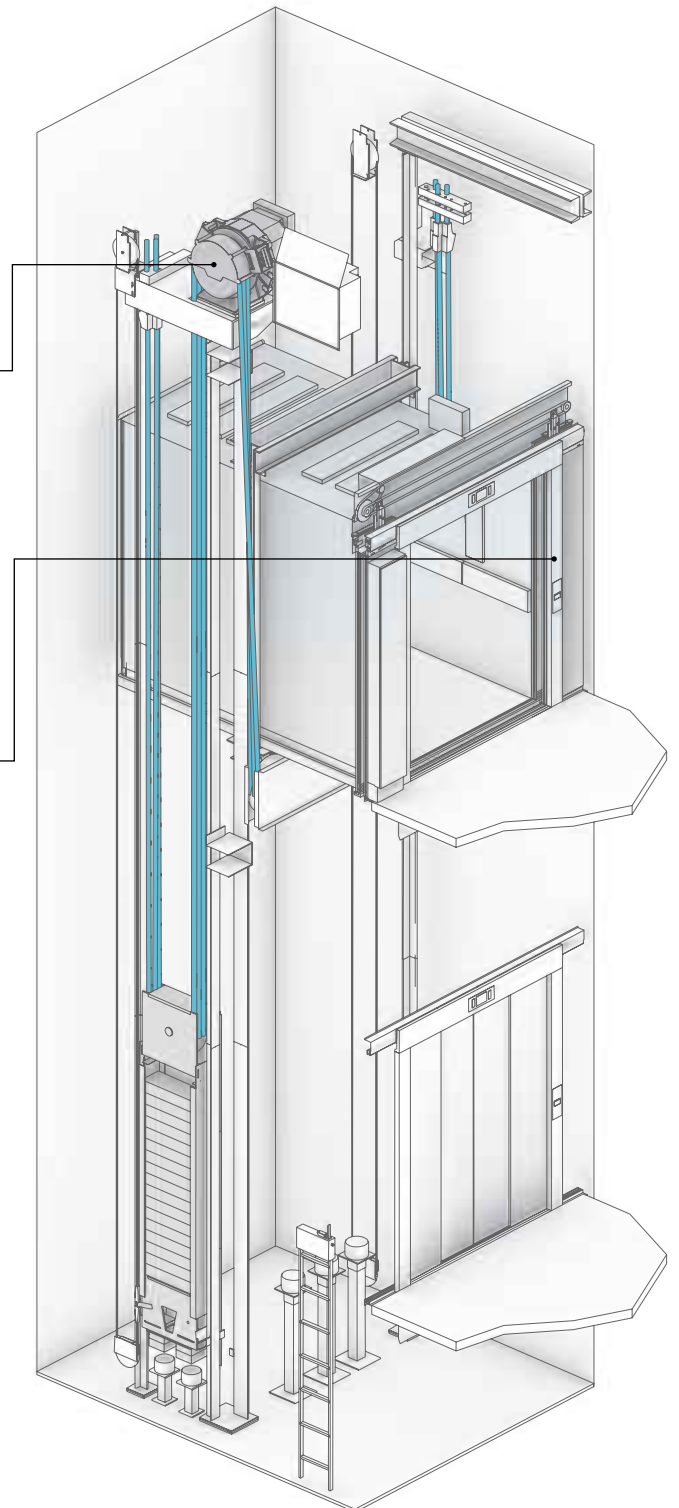

Machine room-less traction elevator

Hydraulic elevator system

The Schindler 2400 can be driven electro-hydraulically with a load of 630 kg to 6300 kg. The hydraulic elevator system offers an extraordinarily economical solution for low rise buildings up to 18 m, particularly for transporting people and shopping trolleys.

Drive

The Schindler 2400 possesses a unique drive system. It consists of a pump unit and an electronically controlled valve. Combined with the integrated control, it reliably fulfills the high demands of a service elevator and provides an extraordinarily comfortable ride. The drive achieves excellent stopping accuracy. The hydraulic version of the Schindler 2400 also displays low energy consumption.

Control

The specially designed microprocessor control is suitable for a wide variety of needs and uses. It offers regulated control, which produces short ride times. You may select from the following typical control types: Pick-up, up or down collective, or collective/selective control for groups of up to four elevators. More than 100 control features are available as standard options.

Access control

The Schindler 2400 possesses access-control systems. Passenger or cargo transport can be controlled according to specific needs – such as by key switch or card reader, for example.

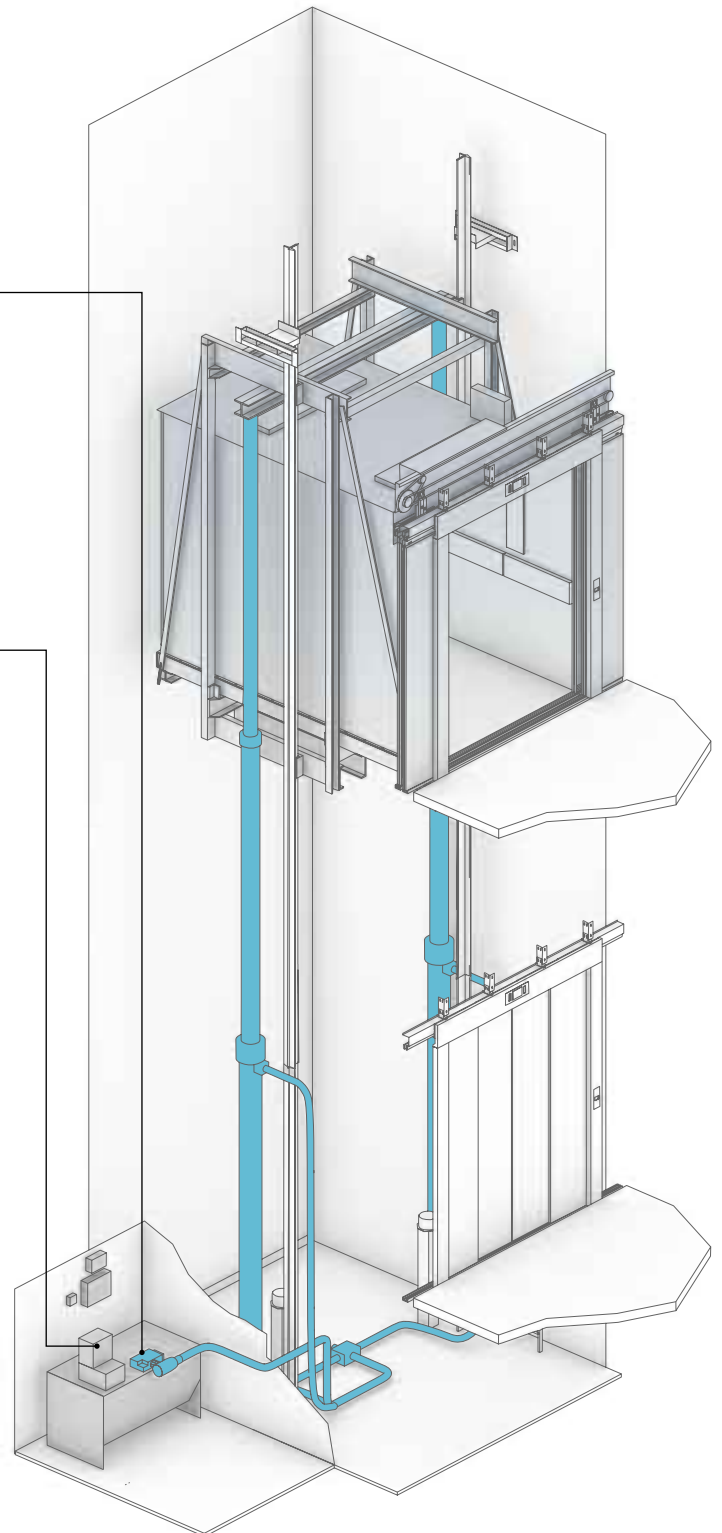

Tandem hydraulic drive

The proof of the pudding is in the eating. Go right ahead.

Drive	Load capacity		Speed	Travel height max.		Number of stops max.		Nominal rating			Car	Door			Shaft	
	GQ kg	Passengers		VKN m/s	HQ m	ZE	^{*3} PMN kW	^{*3} INN A	^{*4} BK mm	^{*4} TK mm		^{*4} HK mm	Type	^{*5} BT mm	^{*5} HT mm	^{*6} HSG mm
Traction^{*1}	1000	13	1.0	50	21	10.8	23	1000–1600	1400–2300	2100–2500	T2/C2/C4	900–1600	2000–2400	1500	HK + 1500	
			1.6	65		18.9	30							1700	HK + 1650	
	1275	17	1.0	50	21	10.8	29	1100–1800	1500–2600	2100–2500	T2/C2/C4	900–1800	2000–2400	1500	HK + 1500	
			1.6	65		18.9	36							1700	HK + 1650	
	1600	21	1.0	50	21	10.8	30	1200–2100	1500–2900	2100–2500	T2/C2/C4	900–2100	2000–2400	1500	HK + 1500	
			1.6	65		22.8	43							1700	HK + 1650	
	2000	26	1.0	50	21	14.2	37	1400–2300	1650–2900	2100–2500	T2/C2/C4/C6	900–2300	2000–2400	1500	HK + 1500	
			1.6	50		22.8	49							1700	HK + 1650	
	2500	33	1.0	50	21	25.0	43	1400–2300	2050–3500	2100–2500	T2/C2/C4/C6	900–2300	2000–2400	1600	HK + 1700	
	3000	39	1.0	24	21	25.0	49	1500–2300	2350–3800	2100–2500	C2/C4/C6	1000–2300	2000–2400	1600	HK + 1700	
3200	42	1.0	24	21	25.0	49	1700–2400	2350–3500	2100–2500	C2/C4/C6	1200–2400	2000–2400	1600	HK + 1700		
3500	46	1.0	24	21	25.0	53	1800–2400	2550–3600	2100–2500	C4/C6	1400–2400	2000–2400	1600	HK + 1700		
4000	53	0.8	24	21	22.8	53	1800–2500	2800–4000	2100–2500	C4/C6	1400–2500	2000–2400	1600	HK + 1700		
Hydraulic Rucksack^{*2}	630	8	0.63	18	8	13.0	32	900–1400	1100–1750	2100–2500	T2/C4	900–1300	2000–2400	1300	HK + 1300	
	1000	13	0.63	18	8	16.0	38	1000–1600	1300–2300	2100–2500	T2/C4	900–1400	2000–2400	1350	HK + 1300	
	1275	17	0.63	18	8	20.0	45	1100–1800	1450–2600	2100–2500	T2/C4	900–1600	2000–2400	1450	HK + 1300	
	1600	21	0.63	18	8	33.0	73	1200–2100	1500–2900	2100–2500	T2/C4	900–1800	2000–2400	1450	HK + 1300	
	2000	26	0.40/0.63	18	8	40.0	86	1400–1500	2350–2900	2100–2500	T2/C4	900–1400	2000–2400	1450	HK + 1300	
Hydraulic Tandem^{*2}	2000	26	0.40/0.63	18	8	40.0	86	1550–2300	1650–2600	2100–2500	T2/C2/C4/C6	900–2300	2000–2400	1150	HK + 1300	
	2500	33	0.40/0.63	18	8	40.0	86	1400–2300	2050–3500	2100–2500	T2/C2/C4/C6	900–2300	2000–2400	1250	HK + 1300	
	3000	39	0.40/0.63	18	8	47.0	98	1500–2300	2350–3800	2100–2500	C2/C4/C6	1000–2300	2000–2400	1250	HK + 1300	
	3200	42	0.40/0.63	18	8	47.0	98	1700–2400	2350–3500	2100–2500	C2/C4/C6	1200–2400	2000–2400	1250	HK + 1300	
	3500	46	0.40/0.63	18	8	60.0	123	1800–2400	2550–3600	2100–2500	C4/C6	1400–2400	2000–2400	1250	HK + 1300	
	4000	53	0.40/0.63	18	8	60.0	123	1800–2500	2800–4000	2100–2500	C4/C6	1400–2500	2000–2400	1250	HK + 1300	
	5000	66	0.40	15	8	47.0	98	1800–3100	2700–4900	2100–2500	C4/C6	1400–3000	2000–2400	1350	HK + 1300	
	6300	84	0.25	15	8	33.0	73	2000–3200	3000–5450	2100–2500	C4/C6	1600–3100	2000–2400	1350	HK + 1300	

GQ Load capacity
VKN Speed
HQ Travel height
ZE Number of stops
PMN Nominal rating
INN Nominal current

^{*1} With or without machine room
^{*2} Machine room under, over, or to the side; max. 10 m from shaft
^{*3} Maximum values

BK Car width
TK Car depth
HK Car height

^{*4} Car dimensions in 50-mm increments, the maximum allowed car area according to EN81 must be considered

T2 Telescope door, two-part
C2 Center-opening telescope door (two-part)
C4 Center-opening telescope door (four-part)
C6 Center-opening telescope door (six-part)
BT Door width
HT Door height

^{*5} Door dimensions in 100-mm increments

HSG Shaft pit depth
HSK Clear overhead below lifting beam

^{*6} Minimal values, in hydraulic variation must be increased in measure according to the configuration

Max. number of entrances: 2, opposing
Number of rides (rope): 180 per hour
Number of rides (hydraulic): 30/60 per hour
Power supply: 400 V; optional 230 V

Shaft width/depth: In the planning section on pages 20–23, ranges shown reflect typical elevator situations.

Schindler 2400 elevators are not designed for trolleys with heavy loads

Car

We construct the car according to your wishes – width, depth and height – so that it perfectly matches the traffic volume in your building. Car frames make the car extraordinarily stable.

Door

We construct the ideal door for your needs – with two, four, or six panels. They efficiently exploit the width of the shaft and, if desired, can be made exactly as high and as wide as the car. This entails a number of advantages. Entering and exiting with shopping carts is convenient. It also helps avoid damage to the doors. And the opening and closing speed of the doors can be adjusted.

Standards

The Schindler 2400 is certified according to the Lift Directive 95/16/EC. In addition, it fulfills all relevant standards:

- EN81-28 Remote emergency calling system for passenger and cargo elevators
- EN81-58 Fire-resistant landing doors
- EN81-70 Accessibility of passenger elevators including persons with disabilities (as an option)
- EN81-71 Protective measures against intentional destruction (optional vandal-proof buttons and car equipment)
- EN81-72 Fire department elevator (optional)

Environment

The Schindler 2400 fulfills the requirements of ISO 14001. Both the traction and the hydraulic versions display very good energy consumption values. For the hydraulic elevators, a drive system can be selected as a standard feature, which has significantly lower energy consumption when compared with conventional hydraulic aggregates.

Monitoring

The Schindler 2400 is permanently monitored from our headquarters, 24 hours a day, 365 days a year. Problems are corrected preventatively.

<p>Walls Car doors</p>	 <p>Skinplate/paint Catania Yellow</p>	 <p>Skinplate/paint Malmo Gray</p>	 <p>Skinplate/paint Lübeck Blue</p>	 <p>Skinplate/paint Aberdeen Green</p>
 <p>Stainless steel brushed</p>	 <p>Stainless steel diamond-pattern</p>	 <p>Stainless steel linen</p>		
				
				
				
<p>Ceiling Floor</p>	 <p>Ceiling Paint Trondheim White</p>	 <p>Ceiling Paint Catania Yellow</p>	 <p>Ceiling Paint Malmo Gray</p>	 <p>Ceiling Stainless steel brushed</p>
 <p>Floor Black studded rubber</p>	 <p>Floor Black structured rubber</p>	 <p>Floor Aluminum treadplate</p>		

To good to be true? Don't worry – this is no fairy tale.

Every day, the Schindler 2400 transports many people in wide variety of building types. In order for it to fit in anywhere, we rely on versatility of design. We present you with standard versions from which to choose, but we're also happy to meet your personal wishes with special materials and colours.

The car walls and doors in the standard version have a high-grade painting in various eye-pleasing colours. The same colours are also available in skinplate. Elegant stainless steel panels are also included in the carefully selected palette of options. We can also offer other colours or materials at similar delivery and price conditions upon request. Walls as well as doors may be partially or completely made of glass if desired.

Landing doors are painted grey, are constructed from stainless steel or, if desired, are in other colour variations available.

For floors in our standard version, textured rubber flooring, black rubber flooring with grey structuring, or aluminium treadplate is available. Upon request, we will gladly install a natural stone flooring for you. The easy-care and slip-proof flooring withstands wear-and-tear and matches the elegant appearance of the elevator car.

A painted ceiling or ceiling of brushed stainless steel are also features of the Schindler 2400. The suspended lighted ceiling provides pleasant lighting in the car.

Simplicity means doing without. Doing without what's unnecessary.

Car and hall fixtures

The control panel in the car of the Schindler 2400 stretches to the entire height of the car. It is embedded flush with the wall of the car. This protects it from damage, such as damage that can occur when entering or exiting with shopping carts, for example.

The car and hall control panels are constructed from brushed stainless steel. The control panels in the car are also available in anthracite. Optional handicapped-accessible control panels for cars with voice-messaging or vandal-proof buttons are also available.

Hall control panels and floor indicators are mounted flush with the wall or into the door frame. The indicators can also be ordered with a gong sound.

Protective strips

The car is equipped with protective strips around its circumference.

They are constructed from

- black plastic,
- brushed stainless steel, or
- are specially constructed according to your wishes.

The baseboard for covering ventilation louvres in the floor are made of brushed stainless steel, and are included as standard equipment.

Thresholds

Car and landing door thresholds made of brushed stainless steel are available as an option.

Handrails

For safety, the goods elevator can be equipped with handrails. They are

- straight or
- bent, and
- are made of brushed stainless steel.

Mirrors

If desired, the Schindler 2400 can be fitted with a mirror. As a standard feature, you can receive mirror that covers upper half of the car's height, placed on whichever car wall you desire.

We also gladly construct additional accessories for you – such as a display window for advertisements – precisely according to your wishes.

Overview of control panels



Floor level indicators
 – Standard
 – Vandal-proof



In-car fixtures, stretched to the entire car height
 – Stainless steel
 – Anthracite
 – Vandal-proof



Hall fixtures, individually configurable
 – 2-element
 – 5-element
 – Vandal-proof

Schindler ID®/Miconic 10



Handrail



Many things can be conceived. Almost anything is possible.

Machine-room-less traction elevator with frequency-controlled drive
1000–4000 kg load capacity; 13–53 persons

Drive	Load capacity		Passengers max.	Speed	Number of entrances			Door			Shaft			
	GQ kg	VKN m/s			BK mm	TK mm	HK mm	Type	BT mm	HT mm	BS mm	TS mm	HSG mm	HSK mm
Traction	1000	13	1.0	1	1100	2100	2300	T2	900	2100	1950	2550	1500	3800
				2		2050						2660		
	1000	13	1.0	1	1300	1750	2300	T2	1100	2100	2200	2200	1500	3800
				2		1700						2310		
	1600	21	1.0	1	1400	2400	2300	C4	1100	2100	2250	2850	1500	3800
				2								3010		
	2000	26	1.0	1	1500	2700	2300	C4	1300	2100	2350	3150	1500	3800
				2		2650						3260		
				2		2700		1500		2500	3230			
	2500	33	1.0	1	1800	2700	2300	C4	1600	2200	2950	3150	1600	4000
				2		2650						3260		
				2		2700		1800		3100	3230			
	3500	46	1.0	1	2100	3000	2300	C4	2000	2200	3400	3450	1600	4000
				2								3610		
	4000	53	0.8	1	2300	3000	2300	C6	2200	2200	3500	3500	1600	4000
				2								3790		

GQ Load capacity
VKN Speed
HQ Travel height
HE_{min} Minimal interfloor distance

BK Car width
TK Car depth
HK Car height

T2 Telescope door
C4 Center-opening telescope door (four-part)
BT Door width
HT Door height

BS Shaft width
TS Shaft depth
HSG Shaft pit depth
HSK Clear overhead below lifting beam

HE_{min} = HT + 740 mm for one-sided entrances
HE_{min} = 300 mm for staggered opposite entrances

For further details, such as offers, construction plans and prices, please contact our sales department directly.

Height and plan view

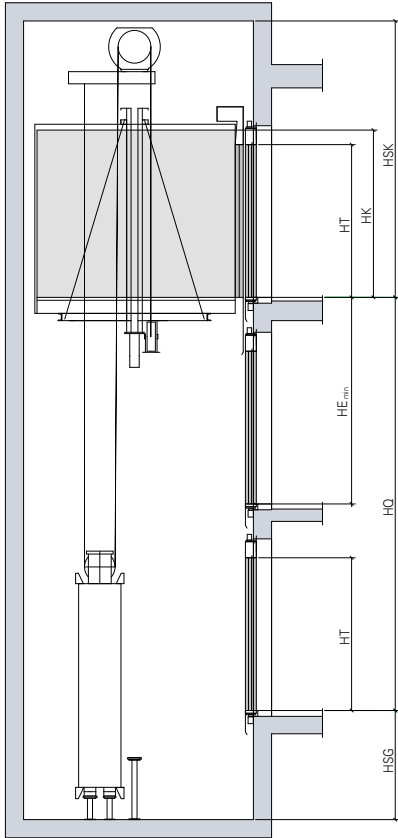

One-sided entrance

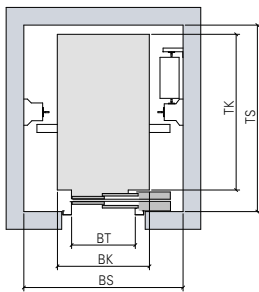

One-sided entrance
Telescopic door

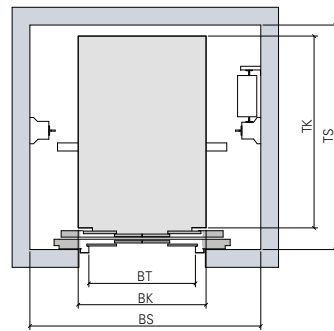

One-sided entrance
Center-opening telescopic door (four-part)

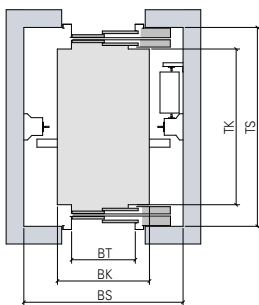

Two-sided entrance
Telescopic door

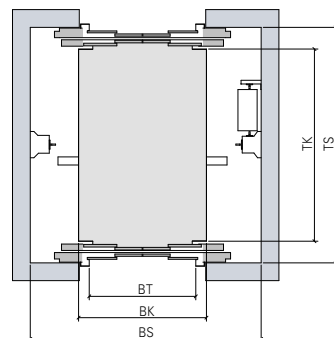

Two-sided entrance
Center-opening telescopic door (four-part)

It's a good feeling, not having to settle for average.

Hydraulic elevator with machine room
630–6300 kg load capacity; 8–84 persons

Drive	Load capacity		Passengers max. Speed	Number of entrances			Door			Shaft				
	GQ kg	VKN m/s		BK mm	TK mm	HK mm	Type	BT mm	HT mm	BS mm	TS mm	HSG mm	HSK mm	
Hydraulic Rucksack	630	8	0.63	1	1100	1400	2300	T2	900	2100	1700	1850	1300	3600
				2		1350						1960		
	1000	13	0.63	1	1100	2100	2300	T2	900	2100	1700	2550	1350	3600
				2		2050						2660		
	1000	13	0.63	1	1300	1750	2300	T2	1100	2100	2000	2200	1350	3600
				2		1700						2310		
	1600	21	0.63	1	1400	2400	2300	C4	1100	2100	2200	2850	1450	3600
				2								3010		
2000	26	0.40	1	1500	2700	2300	C4	1300	2100	2400	3150	1450	3600	
			2		2650						3260			
					2700				1500		2550	3230		
Hydraulic Tandem	2000	26	0.40	1	1500	2700	2300	C4	1300	2100	2400	3150	1150	3600
				2		2650						3260		
				2		2700			1500		2500	3230		
	2500	33	0.40	1	1800	2700	2300	C4	1600	2200	2800	3150	1250	3600
				2		2650						3260		
				2		2700			1800		2950	3230		
	3500	46	0.40	1	2100	3000	2300	C4	2000	2200	3250	3450	1250	3600
				2								3610		
	4000	53	0.25	1	2300	3000	2300	C6	2200	2200	3300	3500	1250	3600
				2								3790		
5000	66	0.25	1	2500	3450	2300	C6	2400	2200	3600	3950	1350	3600	
			2		3400						4190			
6300	84	0.25	1	2500	4200	2300	C6	2400	2200	3600	4700	1350	3600	
			2								4990			

GQ Load capacity
VKN Speed
HQ Travel height
HE_{min} Minimal interfloor distance
BO Width of machine room
TO Depth of machine room

BK Car width
TK Car depth
HK Car height

T2 Telescope door
C4 Center-opening telescope door (four-part)
BT Door width
HT Door height

BS Shaft width
TS Shaft depth
HSG Shaft pit depth
HSK Clear overhead below lifting beam

HE_{min} = HT + 740 mm for one-sided entrances
HE_{min} = 300 mm for staggered opposite entrances

For further details, such as offers, construction plans and prices, please contact our sales department directly.

Height and plan view

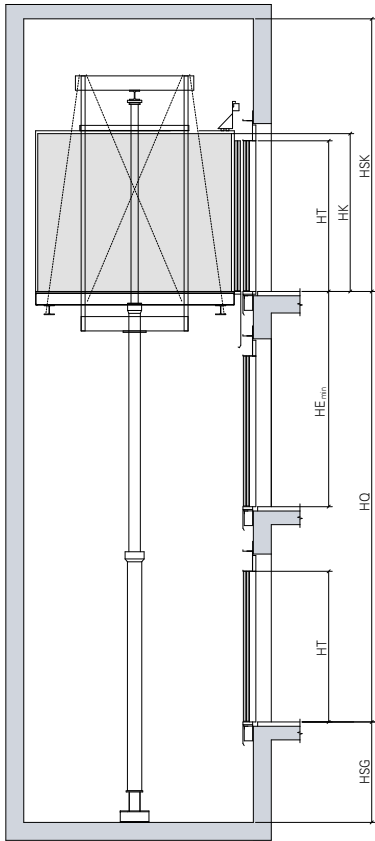

One-sided entrance
Tandem system

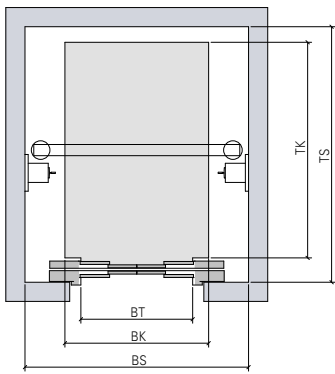

One-sided entrance
Center-opening telescopic door (four-part)

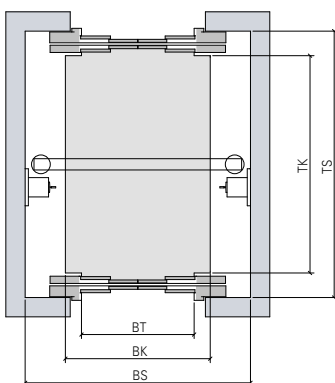

Two-sided entrance
Center-opening telescopic door (four-part)

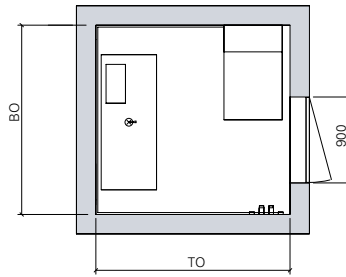

Machine room

It's nice when someone
always makes time for you.
Don't you agree?

For further information including the location
of the distributor nearest you, please visit:

www.schindlerlifts.co.uk

Schindler Ltd
Benwell House
Green Street
Sunbury on Thames
Middlesex
TW16 6QT

Phone: 0044 (0) 1932 758100
Fax: 0044 (0) 1932 758258

