



Schindler 3000

Stylish, functional and flexible





A flexible solution that unifies form and function. An all-round lift applicable to multiple building types, with outstanding architectural flexibility for car, door and shaft dimensions. Swiss precision engineering and latest technologies assure a smooth and safe user experience.



Schindler 3000

Stylish, functional and flexible

Schindler 3000 offers a large variety of design and dimensional combinations from a single product line, and can be tailored to multiple applications in any urban environment. Select from a full spectrum of styles, colours and options to find the best possible match for your building.

Schindler 3000 is part of Schindler's new, modular product range for all buildings, from low to mid-rise, and from simple to sophisticated requirements, worldwide.

Key figures

Capacity	320 - 1275 kg
Travel height	Up to 70 m
Stops	Max 24 stops
Speed	1.0 - 1.75 m/s
Drive system	Machine-room-less, eco-friendly regenerative drive technology, frequency controlled
Group size	Up to 3 cars
Entrances	Front only or through car
Interior	3 interior design lines, fresh wall colours and wide range of fixtures, and bare car option



Designed for comfort

Engineered to Swiss standards for 24/7 operation and smooth ride comfort.

PORT Technology

Optional destination control system with integrated access solution and increased lift efficiency and comfort.

Architectural flexibility

The widest range of applications, plus maximum flexibility in car and shaft dimensions.

Future ready

Lifts designed to interface with next generation technologies.

Multiple design options

Three full design lines to complement your building interior, or choose your own design.

Designed for comfort – built to last

Engineered to Swiss standards

Schindler 3000 is designed, engineered and rigorously tested to ensure smooth, quiet and economical operation throughout your lift's long life cycle, for every application, and in any environment.



Latest technologies, greater comfort

Variable frequency drive systems deliver perfectly controlled power for traction machines and door drives, extending component lifetimes and increasing energy efficiency. Schindler Suspension Traction Media is light and long-lasting, enabling the use of smaller traction machines that reduce energy consumption, noise and vibration levels in the car.

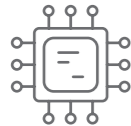

State-of-the-art digital controller

Schindler's scalable (universal) lift controller offers more flexibility in number of openings, number of stops, and car group size. What's more, Schindler's innovative EPIC absolute positioning system for the controller improves both reliability and maintainability for all Schindler controllers.



High-quality – at every level

Contact-free sensors assure millimetre-precise floor levelling for safe, seamless movement of passengers.



Innovative drive technology

Schindler 3000 is equipped with our innovative, regenerative drive technology as standard. The system is designed to reduce energy consumption by up to 30% compared to conventional technology.



Excellent ecological performance

Improving energy efficiency is essential to reduce the environmental impact of lifts and the buildings they serve. Eco-friendly features, such as regenerative drive, LED lighting and stand-by mode while parked, are standard in all Schindler 3000 lifts, achieving the highest energy efficiency rating class A according to ISO 25745-2.*

To give insight into the ecological performance of our lifts throughout their lifecycle, we provide Environmental Product Declarations (EPD). Schindler has registered EPDs at the "International EPD® System" for all major lift product lines, moving an important step further in the assessment of the environmental performance of our products, underlining our continuous efforts towards sustainable solutions.

* The classification always refers to a specific customer configuration. Usage pattern, load capacity, customer specific options & site conditions influence the final rating.

Access control and transit intelligence

The revolutionary PORT Technology

All Schindler 3000 lifts are enabled for our revolutionary PORT Technology, with all the advantages of reduced travel time, higher passenger traffic capacity, and the potential for full building security and personalised access. PORT makes buildings more attractive, more efficient, and more valuable.



Architectural flexibility

Less space, more capacity

Schindler 3000 has outstanding architectural flexibility for car, door and shaft dimensions. Less space for components, more room for you to use profitably.

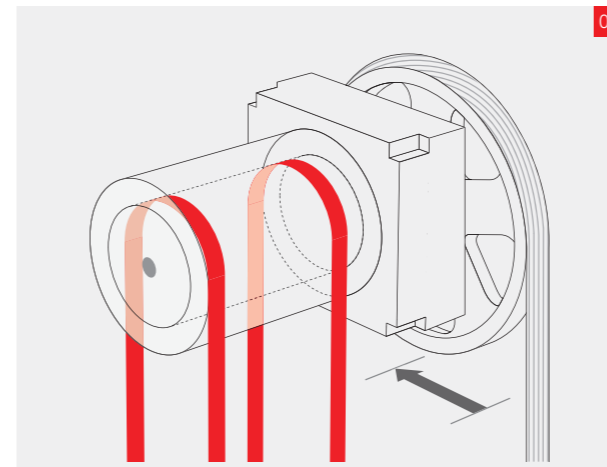
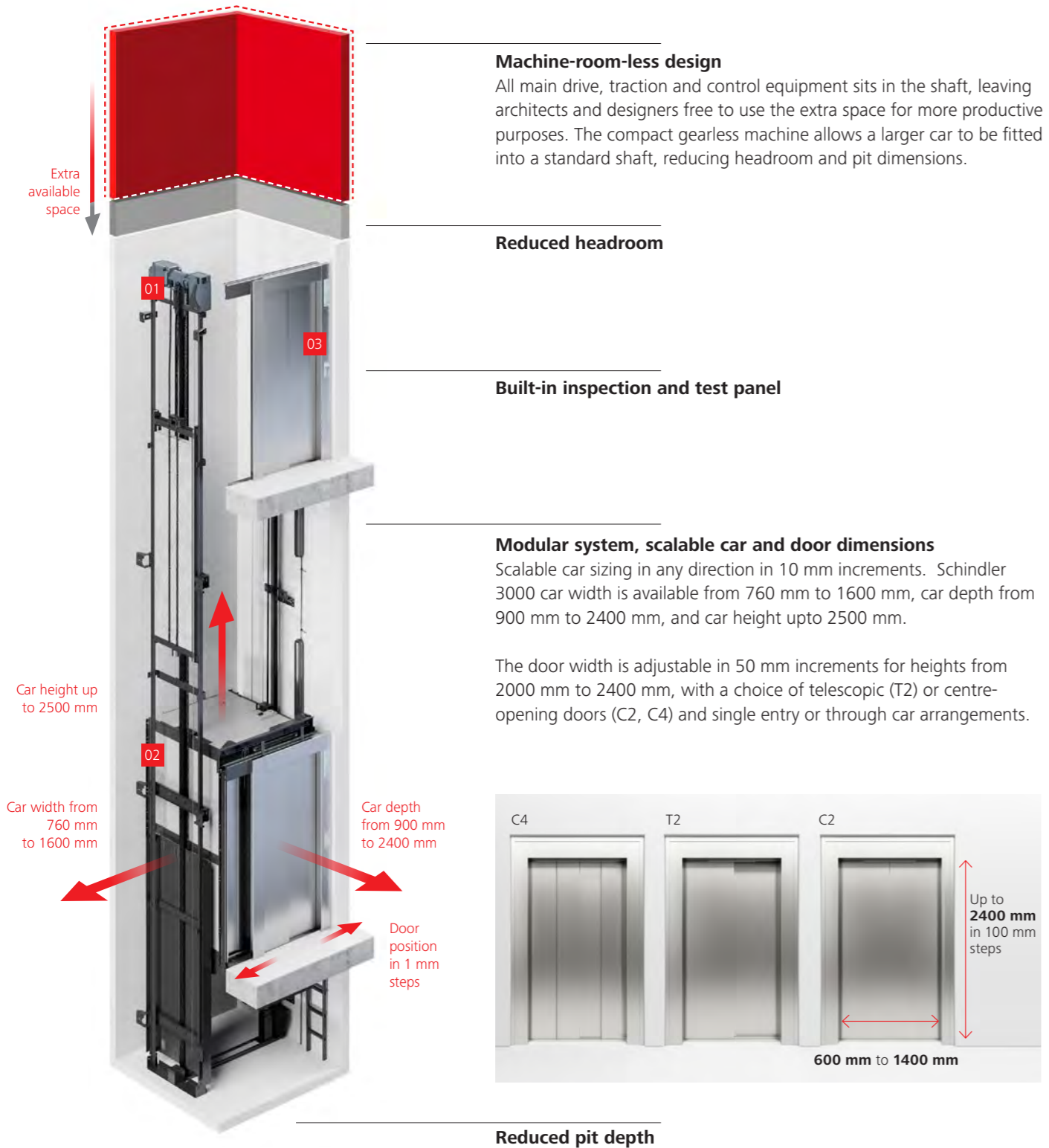

Smaller motor and traction sheave
Schindler's Suspension Traction Media (STM) system guarantees a quieter, smoother ride and does not require any lubrication. STM also saves shaft space as the smaller motor and traction sheave are 70% smaller than traditional systems. Building owners will appreciate the increased reliability and efficiency. STM is provided with halogen-free cabling and wiring.

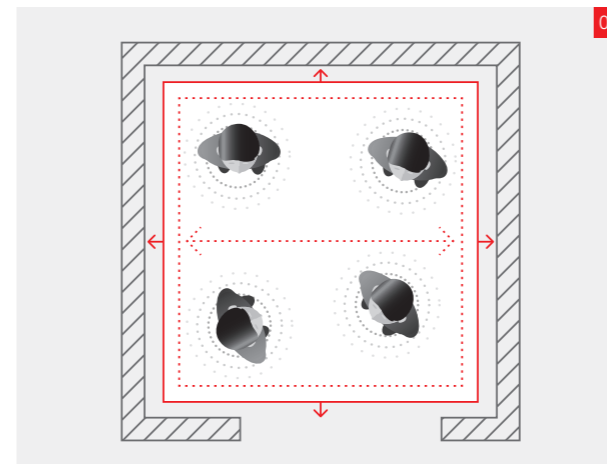

More usable building space
Less space for components, more usable building space and more room for passengers. Schindler 3000 ensures that a standard-sized shaft can carry a wider car with bigger load capacity.



Built-in inspection and test panel
The inspection and test panel is designed to be incorporated into a standard door frame. This solution simplifies lift installation, provides easy access, and saves space. The controller is available with halogen-free cabling and wiring loom as an option.

Future ready

Schindler lifts designed for next-generation technologies

Benefit from our tools, solutions and latest innovations to support you through the entire product life cycle of your lift. Our lifts are designed to use state-of-the-art technologies from planning to operation.



Plan & Design online

With just a few clicks, you can plan just the right lift for your building. Our online **Plan & Design tool** provides you with recommendations, comprehensive product specifications and detailed layout drawings. All of these are compatible with **Building Information Modelling** standards, and with our **Project Cloud** you can share your projects with us.



Innovation in installation

Schindler's **Installation Excellence (INEX)** system not only reduces construction preparation and resources for our customers, it also improves safety and efficiency on site.



Smart operation

All of our new lifts are fully enabled for **Schindler Ahead**, our Internet of Things (IoT) portfolio of services. With Schindler Ahead, we make sure that our customers can step confidently into the digital era.

- **Maximise uptime with Ahead Remote Monitoring**
With digital connectivity, potential issues can be detected and addressed well before service is affected. This helps facility management take timely action to minimise or even avoid downtime. Schindler Ahead maximises uptime thanks to instant, accurate insights.
- **Real-time insights with Ahead ActionBoard**
Schindler Ahead ActionBoard provides operational, performance and commercial information in real time, giving customers clear, instant oversight of their entire lift and escalator portfolio.



User experience on the next level

Inform, engage, entertain. Display engaging multimedia content for your passengers and generate new revenue streams through advertising. Turn your elevator into an infotainment hub with **Ahead SmartMirror** and **DoorShow**.

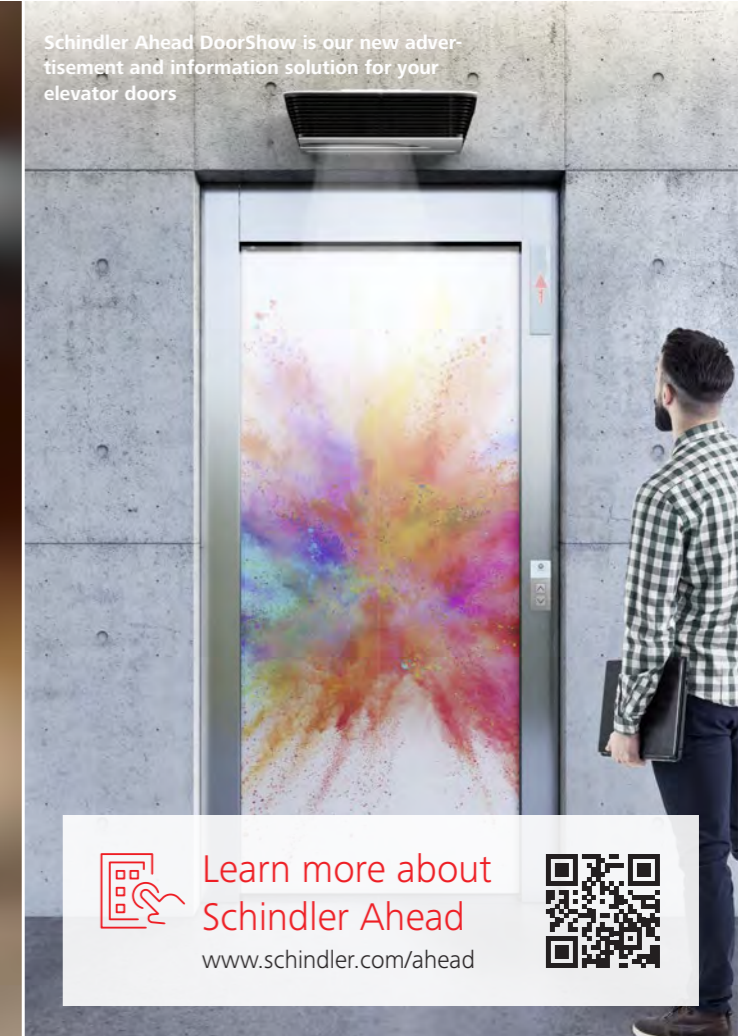

Learn more about
Schindler Ahead
www.schindler.com/ahead





Navona
Functional and durable



Times Square
Modern and versatile

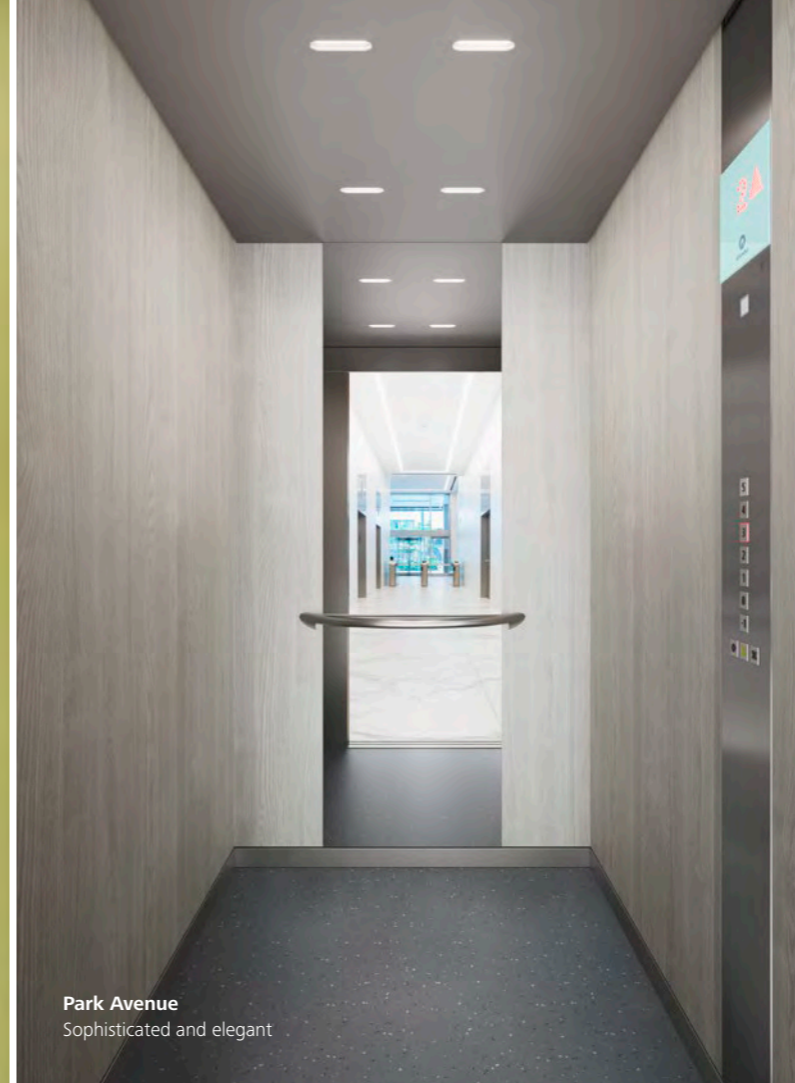

Park Avenue
Sophisticated and elegant



 **Custom design**
Design your own interior

Multiple design options

Ready-made interior design lines

Freedom of design

Create the look and feel you like

Navona

Functional and durable

Clarity and comfort in your lift car with this robust design line. Fresh colours, durable accessories, and the option of five different flooring types make Navona an excellent choice for residential applications. Stainless steel options are also available for rear and side walls.

Times Square

Modern and versatile

A contemporary look. Choose from warm colours or cool colours or a combination of both, to enhance contrast for more depth. Times Square adds distinctive features to any building.

Park Avenue

Sophisticated and elegant

A touch of class. Wooden and textured laminates or back-painted glass walls for a rich, contemporary look with a luxury feel. Stainless steel options are available. Matched lighting completes Park Avenue's elegance.

Choose a lift design that is the perfect match for your building interior. Select from Schindler 3000's three décor lines and combine your choice with our range of operating panels, handrails, lighting, mirrors and other accessories.

For full custom designs, the Schindler 3000 bare car option allows you to add up to 30% of the car's rated load capacity with the materials and finishes of your choice.

Note: Specifications, options and colours are subject to change. All cars and options illustrated in this brochure are representative only. The samples shown may vary from the original in colour and material.

 **Design your lift**
in minutes

Explore the wide range of combinations available with our easy-to-use online configuration tool:
www.schindler.com/plan



Fixtures

Fit your lift with style

Linea 100

Linea 100 offers functional design in stainless steel. The display is integrated in white glass with large, easy-to-read red LED dot matrix. Push buttons illuminate red for call confirmation.

Linea 100 Touch

The convenience of our typical user interface converted to a touch version. Stylish glass design with light indication to signal all functions, and dot matrix displays with large, easy-to-read red LEDs.

Linea 300

An elegant user interface to enhance the look of your lift, with an intuitive, efficient design. The display is in black glass, with buttons positioned on black stainless steel, or white glass display on stainless steel.

The PORT Terminal

The new PORT hall call destination terminals deliver intelligence to your building. A range of PORT terminals is available, with numerous options to optimise traffic flows. PORT terminals offer elegant design, stylish ergonomics and a contemporary look.



Non EN81-70 compliant

- 01 Full height car operating panel *
- 02 Half height car operating panel *
- 03 Car position & direction indicators
- 04 Landing operating panels *
- 05 Horizontal car operating panel *

* EN81-70 compliant

- 01 Car operating panel
- 02 Car operating panel with key switch
- 03 Car position & direction indicators
- 04 Landing operating panels

- 01 Full height car operating panel *
- 02 Car position & direction indicators
- 03 Landing operating panels *

* Contrasting black buttons are available for EN81-70 compliance

- 01 PORT 1 black wall-mounted
- 02 PORT 1 white pedestal
- 03 PORT 4 flush black
- 04 PORT 4 flush grey

Handrails and Mirrors

Spacious and secure

Handrails convey a feeling of security. Schindler stainless steel handrails are designed to blend with car interiors, shapes and textures, and can be mounted to the side and rear walls. A range of handrails is available. To comply with EN81-70 a handrail is required.

Mirrors heighten the sense of space, depth and comfort in lifts. Your lift can be fitted with a half-height safety-glass mirror on the side or rear wall of the car. To comply with EN81-70 a mirror is required.

Landing doors

For a stylish entrance

How your lift design harmonises with your building can enhance passenger response to the overall décor concept. We offer a full range of colours to help you fulfill your building's design potential.

Handrails

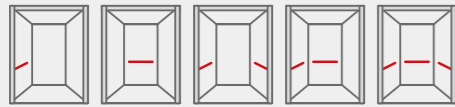

The handrails can be mounted in different combinations of side and rear walls. Different handrail shapes can be chosen according to your preference.

Straight, straight with rounded ends or curved

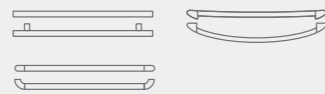

Mirrors

Rear wall

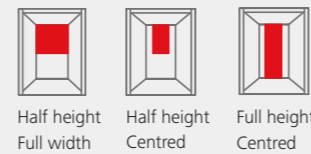

Half height Full width
Half height Centred
Full height Centred

Side wall

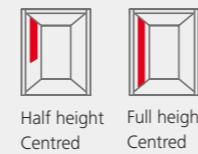

Half height Centred
Full height Centred

Landing arrangements

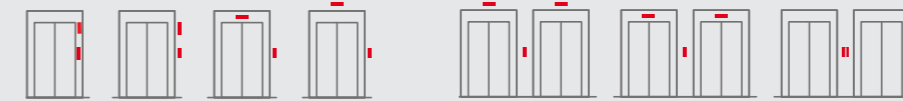

Choose your optimal landing arrangements for simplex, duplex and triplex installations, surface or wall mounting.



Straight Stainless Steel Montreux Polished

Straight with rounded ends Stainless Steel Lucerne Brushed

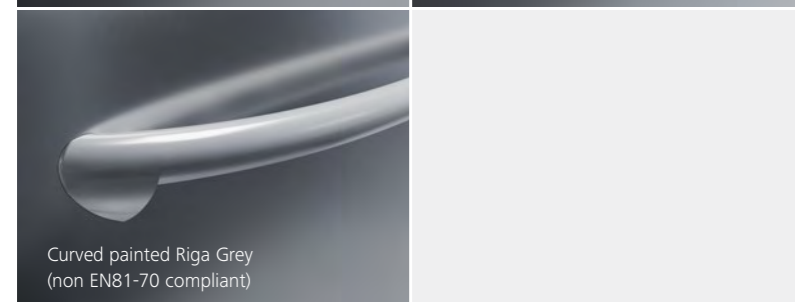

Curved painted Riga Grey (non EN81-70 compliant)

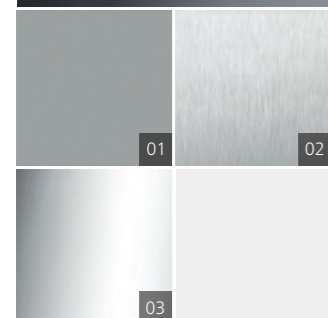

Shapes & finishes

Straight

- 02 Stainless Steel Lucerne Brushed
- 03 Stainless Steel Montreux Polished

Straight with rounded ends & Curved

- 01 Painted Riga Grey
- 02 Stainless Steel Lucerne Brushed
- 03 Stainless Steel Montreux Polished

Continuous

- 02 Stainless Steel Lucerne Brushed



Park Avenue
Laminate Wood Portland Ash walls
Full height centred mirror

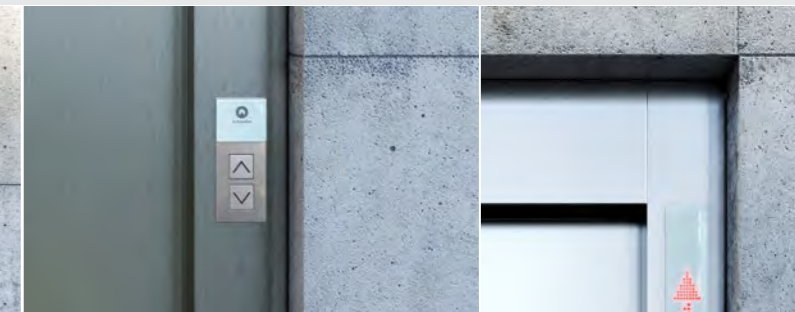

Landing door - colour options

- 01 Painted Pebble Grey
- 02 Painted Polar White
- 03 Painted Riga Grey
- 04 Painted Ruby Red
- 05 Painted Anthracite Grey
- 06 Stainless Steel Lucerne Brushed (304 + 441)
- 07 Stainless Steel Lausanne Linen (304 + 441)
- 08 Stainless Steel Montreux Polished (304)

Glass door - frame colour options

- 06 Stainless Steel Lucerne Brushed (441)
- 06 Stainless Steel Lausanne Linen (304)
- 08 Stainless Steel Montreux Polished (304)

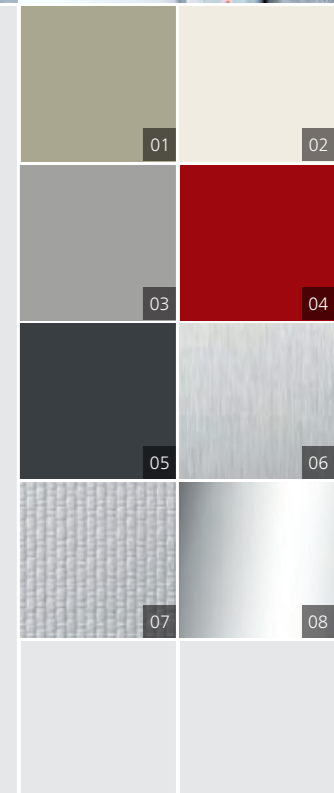

Bumper rails

Preserving your car interior

Schindler 3000 is not designed for the movement of goods, however to protect your lift car walls and prolong their sleek looks, Schindler's bumper rails are available in a variety of heights, and in stainless steel, PVC or wood.

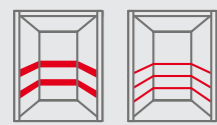

Choose from different heights depending on your requirements. Available in stainless steel, PVC or wood.

01 PVC Coated Black

03 Solid Wood

02 Stainless Steel Lucerne Brushed

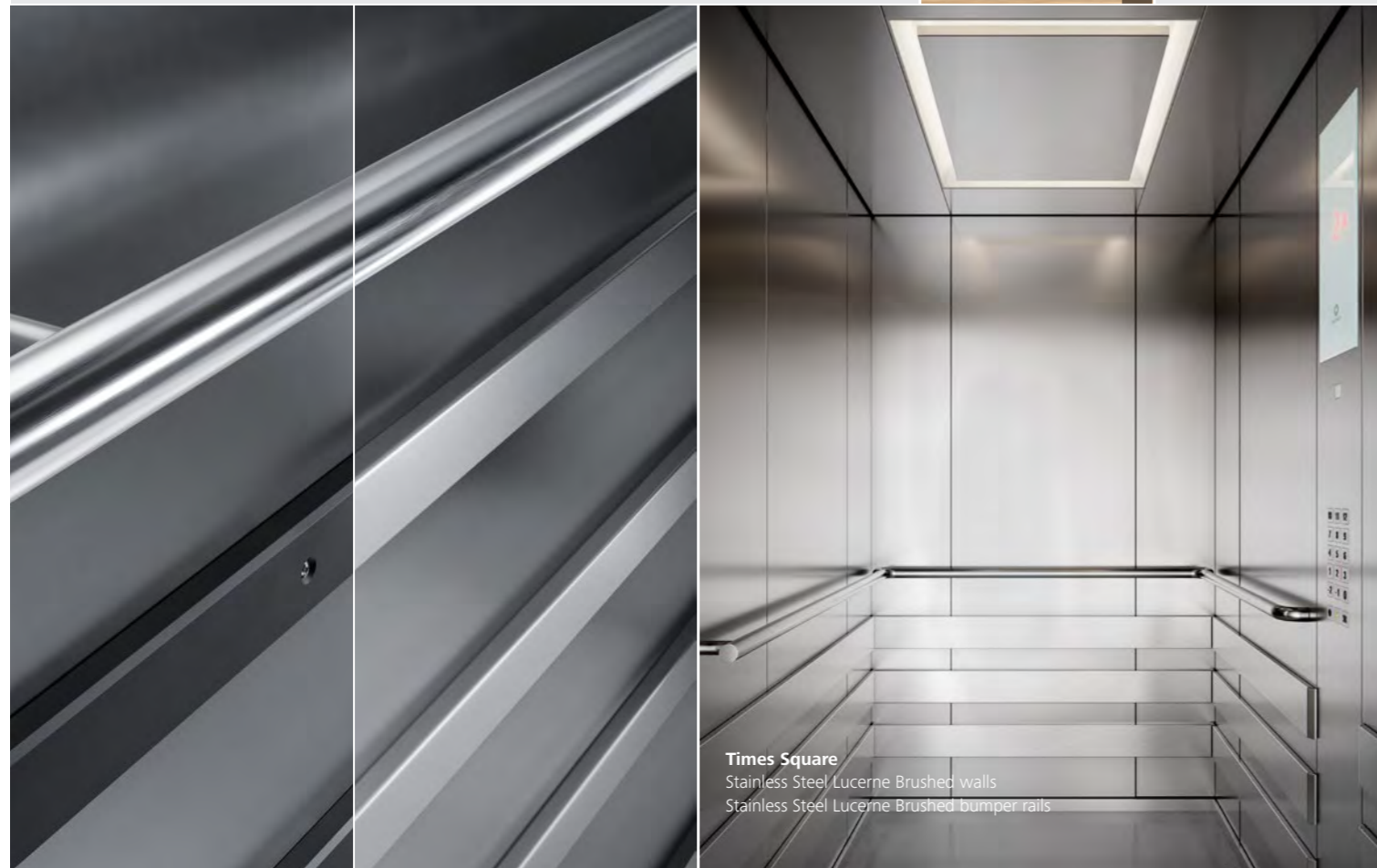
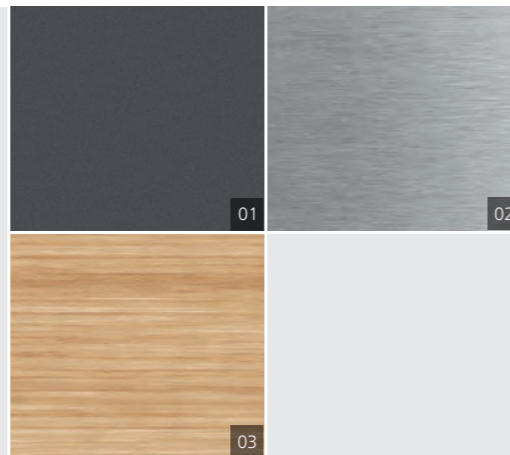

Planning data

Design your lift in minutes

Explore the wide range of combinations available with our easy-to-use online configuration tool: www.schindler.com/plan



Machine room-less traction lift with frequency-controlled drive;

GQ kg	Passengers	VKN m/s	HQ m	ZE	Entrance	Car			Doors		Shaft					
						BK mm	TK mm	HKC mm	Type	BT mm	HT mm	BS mm	TS ⁽¹⁾ mm	TS ⁽²⁾ mm	HSG mm	HSK mm
675	9	1.0	33	10	1, 2	1200	1400	2100	T2	900	2000/2100	1605	1750	1950	1100	3410
675	9	1.0	33	10	1, 2	1200	1400	2100	C2	800	2000/2100	1800	1700	1800	1100	3410
675	9	1.0	33	10	1, 2	1200	1400	2100	C2	900	2000/2100	2000	1700	1800	1100	3410
675	9	1.6	70	21	1, 2	1200	1400	2100	T2	900	2000/2100	1605	1750	1950	1190	3620
675	9	1.6	70	21	1, 2	1200	1400	2100	C2	800	2000/2100	1800	1700	1800	1190	3650
675	9	1.6	70	21	1, 2	1200	1400	2100	C2	900	2000/2100	2000	1700	1800	1190	3620
800	10	1.0	33	10	1, 2	1400	1400	2100	C2	800	2000/2100	1800	1700	1800	1100	3410
800	10	1.0	33	10	1, 2	1400	1400	2100	C2	900	2000/2100	2000	1700	1800	1100	3410
800	10	1.6	70	21	1, 2	1400	1400	2100	C2	800	2000/2100	1800	1700	1800	1210	3620
800	10	1.6	70	21	1, 2	1400	1400	2100	C2	900	2000/2100	2000	1700	1800	1210	3620
900	12	1.0	33	10	1, 2	1400	1500	2100	C2	900	2000/2100	2000	1765	1900	1100	3410
900	12	1.6	70	21	1, 2	1400	1500	2100	C2	900	2000/2100	2000	1765	1900	1210	3620
1000	13	1.0	33	10	1, 2	1100	2100	2100	T2	900	2000/2100	1605	2450	2650	1100	3410
1000	13	1.0	33	10	1, 2	1600	1400	2100	C2	900	2000/2100	2000	1865	1800	1100	3410
1000	13	1.6	70	21	1, 2	1100	2100	2100	T2	900	2000/2100	1605	2450	2650	1210	4020
1000	13	1.6	70	21	1, 2	1600	1400	2100	C2	900	2000/2100	2000	1665	1800	1210	3620
1125	15	1.0	33	10	1, 2	1200	2100	2100	T2	900	2000/2100	1650	2425	2650	1100	3410
1125	15	1.6	70	21	1, 2	1200	2100	2100	T2	900	2000/2100	1650	2450	2650	1210	3620
1275	17	1.0	33	10	1	1200	2300	2100	T2	1000	2000/2100	1800	2655	-	1100	3490
1275	17	1.0	33	10	1, 2	2000	1400	2100	C2	1100	2000/2100	2525	1700	1850	1100	3490
1275	17	1.6	70	21	1	1200	2300	2100	T2	1000	2000/2100	1800	2655	-	1150	3670
1275	17	1.6	70	21	1, 2	2000	1400	2100	C2	1100	2000/2100	2525	1700	1850	1150	3670

GQ	Capacity	BK	Car width	C2	Centre opening, 2 panel	BS	Shaft width
VKN	Speed	TK	Car depth	T2	Side opening telescopic, 2 panel	TS⁽¹⁾	Shaft depth 1 entrance
HQ	Travel height	HKC	Clear car height	BT	Door width	TS⁽²⁾	Shaft depth 2 entrances
ZE	Stops			HT	Door height	HSG	Pit depth
						HSK	Headroom height for safety gear on counterweight HSK min. +70 mm

Maximum 2400 mm Car Height (HKC) available – add 300 mm to Headroom (HSK)

1100 mm doors are available for certain car sizes – please refer to local Schindler representative for further information

Headroom (HSK) dimension is to first striking point (i.e. underside of lifting device)

Shaft dimensions shown at minimum plumb, building tolerances should be added.

Interfloor distance (HE) is:

min. 2400 mm for door height 2000 mm
min. 2500 mm for door height 2100 mm

HE for two-stop installations is min. 2600 mm for door height 2000 mm and 2100 mm

The short interfloor distance (HE min.) for opposite entrances is 300 mm

EC Master Builder Certificate in accordance with Elevator Directive 2014/33/EU



Schindler Plan & Design tool

Design your lift layout in minutes

Our easy-to-use online planning tool makes it simple to find the perfect vertical transportation setup for your building. The Schindler Plan & Design tool helps you to prepare specifications in the early stages of your project life cycle.

With just a few clicks, we provide you with recommendations, a comprehensive product specification, and detailed layout drawings. Simply download the data in DWG or PDF format to enhance your project design. The solution can be integrated with Building Information Modelling standards, and our Project Cloud makes it easy for you to share your projects with us.



www.schindler.com/plan

Schindler Ltd
400 Dashwood Lang Road
Bourne Business Park, Addlestone KT15 2HJ

+44 (0) 1932 758100
marketing.gb@schindler.com
www.schindlerlifts.co.uk

This publication is for general information purposes only and we reserve the right at any time to alter the services, product design and specifications. No statement contained in this publication shall be construed as a warranty or condition, expressed or implied, as to any service or product, its specifications, its fitness for any particular purpose, merchantability, quality or shall be interpreted as a term or condition of any service or purchase agreement for the products or services contained in this publication. Minor differences between printed and actual colours may exist.

We Elevate



Schindler